

entervo.pay

Automatic Pay Station for flexible Payment Options and Media Technologies

Intended Use:

The entervo.pay automatic pay station makes an impression through its contemporary and user-friendly design, and stands out due to its high degree of flexibility.

Evaluation of parking media based on the proven barcode, magstripe or Scheidt & Bachmann ChipCoin technology is complemented by new media like 2D barcodes, RFID technology and license plates.

Optionally, alongside the classic payment with coins, banknotes or credit cards can be accepted.

During operation, the pay station proves itself user-friendly time and time again. This is due to its large touch screen monitor and the easy to understand payment process that utilizes recognisable symbols.

Thanks to the "Green Efficiency" technology with energy efficient hardware concepts, power consumption can be reduced by up to 70%.

Dimensions (mm):

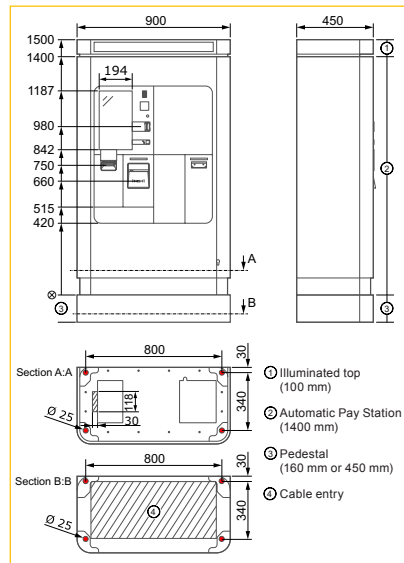

TECHNICAL SPECIFICATIONS

User guidance:	<ul style="list-style-type: none"> Vertically mounted touch screen monitor (39.6 cm / 15,6", 768 x 1366 pixels) Intuitive user guidance via symbols and multilingual text LED Lighting strips for accentuation of operating elements Illuminated issue tray Intercom substation with call button, microphone and loudspeaker (8Ω)
Media technologies:	<ul style="list-style-type: none"> BKV40 for processing barcode tickets TPU for processing barcode and/or magstripe tickets ChipCoin processing for Scheidt & Bachmann ChipCoins based on HiTag Detailed information can be found in the corresponding components' data sheets
Coin processing:	<ul style="list-style-type: none"> Electronic coin acceptor for up to 16 different types of coin 4 self-filling change stores (hoppers) for each type of coin Capacity: 2 change stores which hold 290 coins and 2 which hold 560 coins (Reference values based on 1€ coins. Smaller/larger coins differ) Issue of 4 different types of coin Self-locking coin box made out of stainless steel, content 7 litres for approx. 5,700 coins Optionally with up to 3 additional change stores (hoppers) for up to 1,200 coins respectively
Banknote processing systems:	<ul style="list-style-type: none"> Please refer to the overview "Banknote Processings"
Cashless means of payment:	<ul style="list-style-type: none"> Various payment terminals can be integrated
Receipts:	<ul style="list-style-type: none"> Printed on standard thermal paper roll
Behaviour in the event of network failure:	<ul style="list-style-type: none"> In case of a network failure, the Automatic Pay Station will store up to 10,000 payment transactions
Housing:	<ul style="list-style-type: none"> Stainless Steel Housing / Ingress Protection Rating according to IEC 60529: IP43 Option of integrating pedestal made of galvanized sheet steel (450 mm or 160 mm high)
Standard colours:	<ul style="list-style-type: none"> Front panel: RAL 7043 (traffic grey B) Housing: RAL 1003 (signal yellow) or RAL 9016 (traffic white) / Special colour according to S&B colour range available as an option
Illuminated tops (option):	<ul style="list-style-type: none"> Optional LED-illuminated top with backlit lettering
Connections / power supply:	<ul style="list-style-type: none"> Power supply (100-240VAC ±10%, 50-60Hz) / Network (LAN) / Intercom
Power consumption (approx.):	<ul style="list-style-type: none"> Basic configuration: 50W / additional 500W during heating mode / Illuminated top: 14W
Place of installation:	<ul style="list-style-type: none"> USA: Protected locations or indoor use Canada: Suitable for indoor use only All other countries: Protected locations or indoor use; also suitable for outdoor use if the device is equipped with a special rain protection kit Display must be protected from direct solar radiation Temperature range: -15 °C ... +50 °C / Relative humidity: ±0% ... 95%
Weights (approx.):	<ul style="list-style-type: none"> Pay Station: 250 kg / Steel pedestal: 13 kg (160 mm) - 25 kg (450 mm)
Approvals and conformity:	<ul style="list-style-type: none"> Approval name according to name plate affixed to the device: PKA40 Europe: CE Mark USA/Canada: NRTL approval by TÜV SÜD America Inc.; Certificate No. U8 17 10 28197 030
Extras:	<ul style="list-style-type: none"> Special locks / Transponder reader / Front-facing 2D barcode scanner for eTickets (print@home) Other special equipment upon request

File name: PAYSTATION_DATA_entervo.pay_8693400_q_0_en_CB.pdf / Illustrations and descriptions may also include special options.